

USN

--	--	--	--	--	--	--	--	--	--

10EC63

Sixth Semester B.E. Degree Examination, Feb./Mar. 2022
Microelectronics Circuits

Time: 3 hrs.

Max. Marks:100

Note: Answer any FIVE full questions selecting THREE full questions from Part-A and any TWO full questions from Part-B.

PART - A

- 1
 - a. With neat diagram, derive an expression for drain current both in triode and saturation region. What happens to i_d if channel length modulation is considered? (10 Marks)
 - b. For an $0.8\mu\text{m}$ technology for which $t_{\text{OX}} = 15\text{nm}$, $\mu_n = 550 \text{ cm}^2/\text{V}$. Find k'_n and c_{OX} and the overdrive voltage $V_{\text{ov}} = V_{\text{as}} - V_t$ required to operate a transistor having $W/L = 20$ in saturation with $I_D = 0.2 \text{ mA}$. What is the minimum V_{DS} needed? (06 Marks)
 - c. Explain the operation of drain to gate feedback resistor circuit. List the merits and demerits. (04 Marks)

- 2
 - a. Draw the CG amplifier circuit, its equivalent circuit. Also derive the expressions for input resistance, output resistance, voltage gain, open circuit voltage gain and overall voltage gain. (10 Marks)
 - b. Using the equivalent circuit, find the values of R_{in} , R_{out} , A_v , A_{v_o} and G_v for the circuit shown in Fig.Q.2(b).

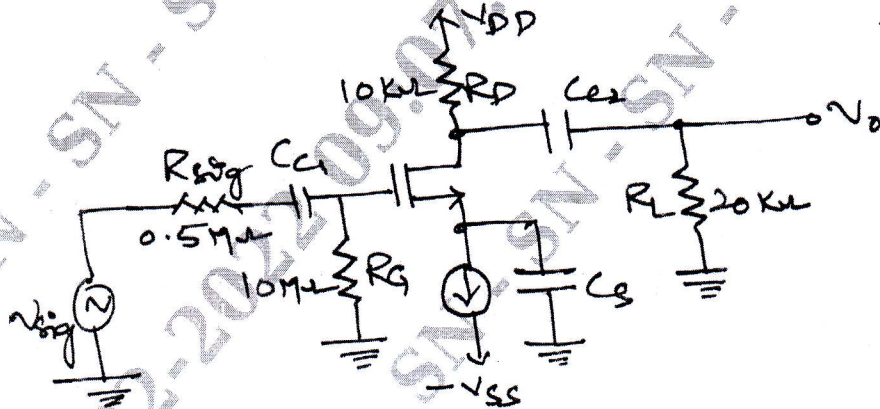

Fig.Q.2(b)

Assume $g_m = 2\text{mA/v}$, $r_o = 50\text{K}\Omega$

(10 Marks)

- 3
 - a. What is meant by current mirror? With a circuit and graph explain MOSFET current mirror circuit. (06 Marks)
 - b. Explain briefly MOSFET current steering circuit. (10 Marks)
 - c. Implement current source circuit using BJT. (04 Marks)

Important Note : 1. On completing your answers, compulsorily draw diagonal cross lines on the remaining blank pages.
2. Any revealing of identification, appeal to evaluator and /or equations written eg, 42+8 = 50, will be treated as malpractice.

- 4 a. Define a cascade amplifier. Explain the small signal analysis of a MOS cascade amplifier with equivalent circuit diagram. (10 Marks)
b. What is a Wilson current mirror? Analyze the circuit to determine its output resistance. (10 Marks)
- 5 a. Draw the circuit for MOS differential pair with a common mode input voltage and explain its working. (06 Marks)
b. Show that CMRR is infinite in case of MOS differential amplifier when matched perfectly. (06 Marks)
c. With a neat figure explain 4-stage bipolar opamp. (08 Marks)

PART – B

- 6 a. Explain the four basic feedback topologies. (06 Marks)
b. Draw the ideal structure and equivalent circuit for the series-shunt feedback amplifier and explain it. (08 Marks)
c. Write a note on the effect of feedback on amplifier poles. (06 Marks)
- 7 a. Derive the expression for closed loop gain in non-inverting opamp. (06 Marks)
b. With neat circuit diagram, explain operation of instrumentation amplifier. (10 Marks)
c. Design an inverting amplifier having a gain of -10 and input resistance of 100K Ω . (04 Marks)
- 8 a. Implement OAI gate for the function $F = \overline{(A + B)(C + D)}$ (06 Marks)
b. Explain charge sharing problem in dynamic 3-input NAND circuit. (10 Marks)
c. Design domino 2-i/p AND gate with the help of basic domino logic circuit. (04 Marks)
